

## ICIREST-19 Design and Power Management of Hybrid Renewable System for Energy Sustainability

Priyanka M.Dhawade, Prof.Bhushra Khan

Department of Electrical Engineering Abha Gaikwad Patil College of Engineering, Nagpur, Maharashtra  
Department of Electrical Engineering Abha Gaikwad Patil College Of Engineering Nagpur, Maharashtra

**Abstract:** Hybrid Renewable Energy Power Generation System focusing on Energy sustainability. It have been introduced to overcome intermittent nature of single source renewable energy generation .A number of challenges and future research in relation to hybrid renewable energy systems are addressed to sustain renewable energy system.

**Keywords:** Hybrid energy system,generation unit sizing,Energy management,,Renewable Energy,energy storage.

### I. Introduction

Electric energy is one of the important requirements of any country because it has a vital influence on their social and economic development. A significant portion of energy demand has been heavily dependent on fossil fuels like natural gas, coal and etc. The mentioned conventional energy sources have a number of drawbacks such as the great volatility in costs, limited and inadequately distribution on the earth's crust, harmful emissions and etc. On the other hand, rapid increase in energy demand has led to a gap between production and demand of energy. To solve the problems raised, renewable energy resources such as wind, photovoltaic (PV), micro hydro and etc., can be a suitable solution. Due to intermittent nature of many renewable energy sources and their dependence on environmental conditions, hybrid combinations of two or more of renewable energy sources can improve system's performance [12, 13]. Hybrid renewable energy systems can work in stand-alone or grid connected (GC) mode. Hybrid renewable energy systems have main advantages in comparison. To single source system , Some of these benefits have been. In this paper, paradigms and common methods available for control and energy management of Hybrid renewable energy systems are reviewed and compared with each other. An optimal energy management strategy ensures a cost effective and reliable integrated energy system. Typically, a control system is required to determine and assign active and reactive output power dispatch from each energy source while keeping its output voltage and frequency at the desired limit. Most of the authors used storage state of charge, bus voltage and bus frequency as control parameters for energy flow management in HRES. To develop an intelligent energy flow Management in Hybrid renewable energy systems, renewable energy sources and load are forecasted at first stage and optimized at second stage. The control systems can be classified into three categories via: centralized, distributed and hybrid control paradigms and in all of them, each energy source is assumed to have its local controller that can determine optimal operation of the corresponding unit based on current information [7, 13-15].

### II. Hybrid energy system configuration

#### A. Integration schemes

A robust micro grid should also have "plug-and-play" operation capability .Adapted from the concept widely used in computer science and technology, plug-and-play operation here means a device DG, an energy storage system, or a controllable load) capable of being added into an existing system (micro grid) without requiring system reconfiguration to perform its designed function,Namely , generating power, providing energy storage capacity, or carrying out load control. A suitable system configuration and a proper interfacing circuit [also called power electronic building block (PEBB)] may be necessary to achieve the plug-and-play function of a DG system [36], [37].

There are many ways to integrate different AE power generation.

#### B. sources to form a hybrid system. Maintaining the Integrity of the Specifications

AC coupling can be divided into two subcategories: PFAC-coupled and HFAC-coupled systems. The schematic of a PFAC-coupled system is shown in Fig. 2(a), where the different energy sources are integrated through their own power electronic interfacing circuits to a power frequency ac bus. Coupling inductors may also be needed between the power electronic circuits and the ac bus to achieve desired power flow management.

In this scheme, the different energy sources are coupled to an HFAC bus, to which HFAC loads are connected. This configuration has been used mostly in applications with HFAC (e.g., 400 Hz) loads, such as in airplanes, vessels, submarines, and in space station applications.

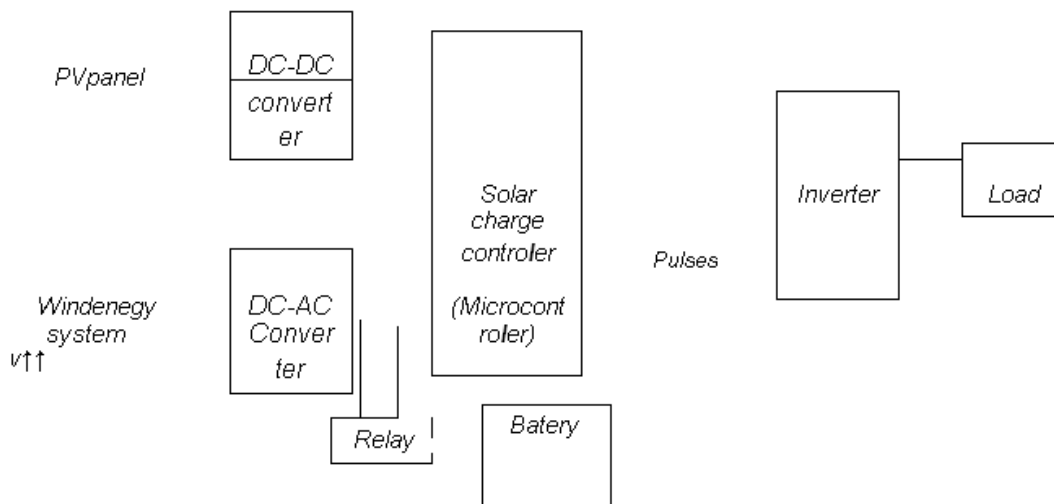

In both PFAC and HFAC systems, dc power can be obtained through ac/dc rectification. The HFAC configuration can also include a PFAC bus and utility grid (through an ac/ac or a dc/ac converter), to which regular ac loads can be connected.

## II. challenge the vision for future

- 1) Storage technology is critical for ensuring high levels of power quality and energy management of stationary hybrid RE systems. The ideal storage technology would offer fast access to power whenever needed, provide high capacity of energy, have a long life expectancy, and is available at a competitive cost. However, there is no energy storage technology currently available that can meet all these desirable characteristics simultaneously. In this section, the different types of energy storage devices and systems are covered without going into the details of operation of any specific device. The operational performance and applications of energy storage devices for advanced power applications (also, equally suited for hybrid RE/AE power generation system applications) are, for example, discussed .

### A. Unit sizing and technology selection

Component sizing of hybrid RE/AE systems is important and has been studied extensively. Selection of the most suitable generation technologies (RE/AE/conventional sources) for a particular application is also equally important. Available application software can be used to properly select generation technologies. Unit sizing and technology selection can sometimes be as straightforward as meeting certain simple requirements such as using the available generation technology and not exceeding the equipment power rating, or it can be as complex as satisfying several constraints and achieving several objectives to maximum extent at the same time. Normally, based on available statistical information about generation, load, financial parameters (e.g., interest rate), geographic factors, desired system reliability, cost requirements, and other case-specific information, generation technologies and their sizes can be optimized to satisfy specific objective functions, such as minimizing environmental impact, installation and operating costs, payback periods on investment, and/or maximizing reliability. Power system optimization methods such as linear programming (LP) [49], interior point method (IPM) [50], and heuristic methods such as genetic algorithms and particle swarm optimization (PSO) can be used for component sizing and energy management of hybrid RE/AE systems [51]–[56]. These techniques are especially attractive when multiple objectives are to be met, some of which may be conflicting, e.g., minimizing cost, maximizing system availability and efficiency, and minimizing carbon emission.

## III. Using the Template

Excitonic solar cells used in the hybrid renewable energy system Nanotechnology use in this system to improve sustainability. Hydrogen gas will be used.

Fig. 1. Example of a figure caption. (*figure caption*)

Figure Labels: fig .shows hybrid renewable energy system dc.

### **Acknowledgment**

The authores wish to acknoeledge the valuable contribution of dr.z.ziang to control energy ,management system to improve the wisdom of the renewable energy system.

### **References**

- [1]. review of hybrid renewable energy system by m.h.nehrir.c.wang
- [2]. J. Clerk Maxwell, A Treatise on Electricity and Magnetism, 3rd ed., vol. 2. Oxford: Cla
- [3]. I.S. Jacobs and C.P. Bean, "Fine particles, thin films and exchange anisotropy," in Magnetism, vol. III, G.T. Rado and H. Suhl, Eds. New York: Academic, 1963, pp. 271-350.